



nyloflex[®] Dryer FV

Premium quality system for drying of photopolymer flexo printing plates

Wide web format, suitable for processing high quality photopolymer plates up to a maximum size of 1320 x 2032 mm (52.0" x 80.0")

Excellent productivity and consistency

- uniform temperature distribution through the separate drying chambers
- easy designed operation panel displays all necessary times and settings, e.g. individual digital timer and count down facility for each drying drawer
- highly efficient exhaust air extraction system with safety shut-down facility prevents solvent vapours from escaping during drying
- high powered heating output of 13.8 kW to quickly achieve the necessary operating temperature
- excellent build quality offers a long service life

Ecologically friendly and economical

- two chamber design with individual temperature control for energy saving and efficiency
- low energy consumption due to good heat insulation

Easy and comfortable handling

- easy to operate via display
- six drying drawers with wide opening
- programmable digital timer for each drawer to allow the input of different drying times
- audio alarm to signal end of drying time
- automatic shut down is possible

nyloflex® Dryer FV

Equipment dimensions

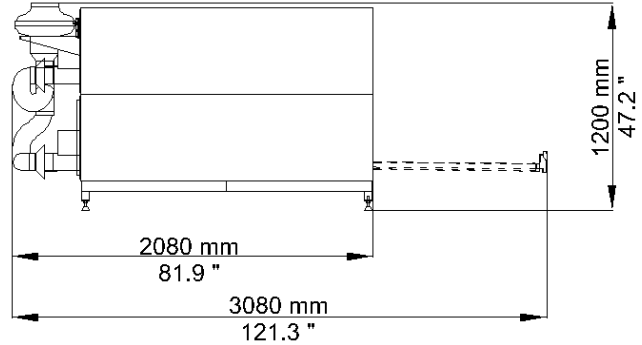
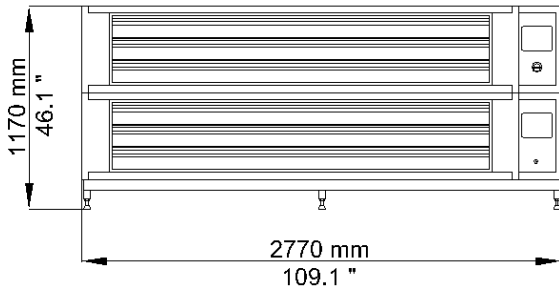

Technical data	nyloflex® Dryer FV
Maximum plate size (W x L)	2032 mm x 1320 mm (80.0" x 52.0")
Electrical connection	230 V, 50/60 Hz (3 Ph/PE) / 400 V, 50/60 Hz (3 Ph/N/PE)
Nominal current	36 A / 24 A
Nominal power	15.2 kW
Exhaust air flow rate	min. 450 Nm ³ /h (265 CFM) NW 160 mm (6.3")
Weight (approx.)	1020 kg (2250 lbs) net 1540 kg (3395 lbs) gross
Crate dimensions (W x D x H)	3090 x 2260 x 1580 mm (121.7" x 81.1" x 62.2")
Recommended ambient temp.	20 - 25 °C (68 - 77 °F)



**ANDERSON &
VREELAND INC.**

T: 866.282.7697 • F: 800.223.6869
www.AndersonVreeland.com • info@AndVre.com

All information in this document is based on our present knowledge and experience at the time of printing. Due to the multitude of factors influencing the processing and application of our products, it does not exempt the user from testing and calibrating. Nor does it imply any legally binding assurance concerning specific properties of the products or the suitability for a particular application. The responsibility of observing any possible industrial property rights, laws and regulations is the obligation of the user. Subject to technical changes without prior notice. Product names marked ® are registered trademarks of Flint Group.